



Overview

Flok al B.V. TURBINE Flowmeter series FMT measures liquid, gas and steam with low viscosities with high accuracy.

- Low Cost
- Outstanding Accuracies of 0.2%, 0.5% and 1%
- Bi-directional Flow capacity (optional)
- Various Signal Output options of Pulse and 4-20mA
- Wide application for liquid, gas and steam in the fields of petroleum, chemical industry, metallurgy, etc. for measuring and control

Specifications

- Accuracy** Liquid: $\pm 0.2\%$, 0.5% and 1%
 Gas: $\pm 1\%$ (0.5%, Optional)
- Medium Temperature** Liquid: $-20^{\circ}\text{C} \sim +120^{\circ}\text{C}$
 Gas: $-20^{\circ}\text{C} \sim +60^{\circ}\text{C}$
- Ambient Temperature** Liquid: $-20^{\circ}\text{C} \sim +55^{\circ}\text{C}$
 Gas: $-20^{\circ}\text{C} \sim +50^{\circ}\text{C}$
- Max. Operating Pressure** ≤ 2.5 Mpa
- Power Supply** 5~ 24VDC, Battery
- Output: 4-20mA, Pulse**
- Explosion-proof** Ex d II B T4



**Turbine Flow Meter
(Series FMT)**

Turbine Flow Meter



Flanged In-line sensor with Indicator



Screw In-line sensor



Insertion sensor



Specifications Table for Liquid Type

DN (mm)	Flow Range (m ³ /h)						Medium Temp. (°C)	Ambient Temp. (°C)	Max. Pressure (MPa)	Pressure Loss (MPa)
	Accuracy 0.2%		Accuracy 0.5%		Accuracy 1.0%					
	Min.	Max.	Min.	Max.	Min.	Max.				
2A					0.03	0.16	-20°C ~ +120°C	-20°C ~ +55°C	6.3	0.12
4A					0.04	0.25				
6A					0.1	0.6				
10A					0.2	1.2				
15A			0.6	4	0.6	6				
25A			1.6	10	1	10				
40A	3	20	3	20	2	20			2.5	0.025
50A	6	40	6	40	4	40				
80A	16	100	10	100	10	100				
100A	25	160	20	160	20	200				
150A	50	300	40	300	40	400				
200A			100	600	80	800			1.6/ 2.5	0.025
250A			160	1000	120	1200				
300A			260	600	180	1800				

Specifications Table for Gas Type

DN (mm)	Normal Flow Range (Am ³ /h)		Accuracy	Medium Temp. (°C)	Ambient Temp. (°C)	Max. Pressure (MPa)	Pressure Loss (MPa)
	Min.	Max.					
15A	1.5	7.5	2.5%	-20°C ~ +60°C	-20°C ~ +50°C	6.3	0.001
25A	6	42					
40A	8.4	84					
50A	16.8	168	1%				
80A	34	340					
100A	51	510					
150A	98	980					
200A	170	1700					
250A	230	2300					
300A	400	4000					

Specifications Table for Insertion Type

Model	Velocity Range (m/s)		Medium Temp. (°C)	Ambient Temp. (°C)	Max. Pressure (MPa)	Pipe Size (mm)
	Liquid (Accuracy 1%)	Gas (Accuracy 2.5%)				
IS800	0.3 ~ 3.5	5 ~ 50	-20°C ~ +120°C	-25°C ~ +55°C	1.6	50 ~ 800
IS2000	0.3 ~ 3.5	5 ~ 50			1.0	50 ~ 2000

Dimensions of Converters (Flow Indicators)

Pulse Transmitter-No Display
Non-Exproof

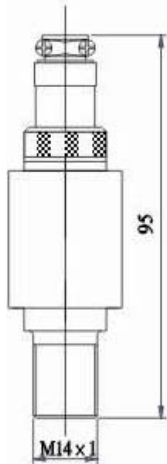

Cables connected by soldering

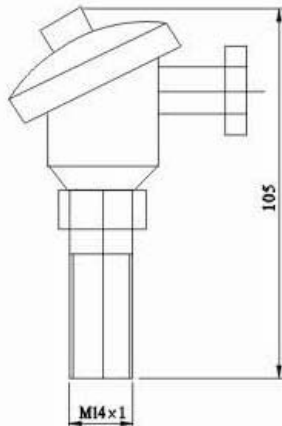

Cables connected thru terminals

4-20mA & Pulse Transmitter-No Display
Ex-Proof

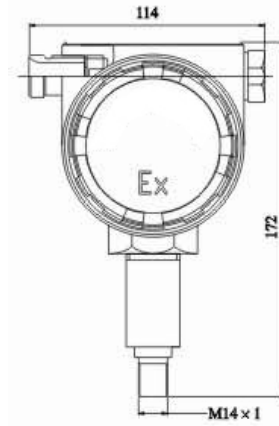

Rate & Total Display
No Signal Output – Battery Powered

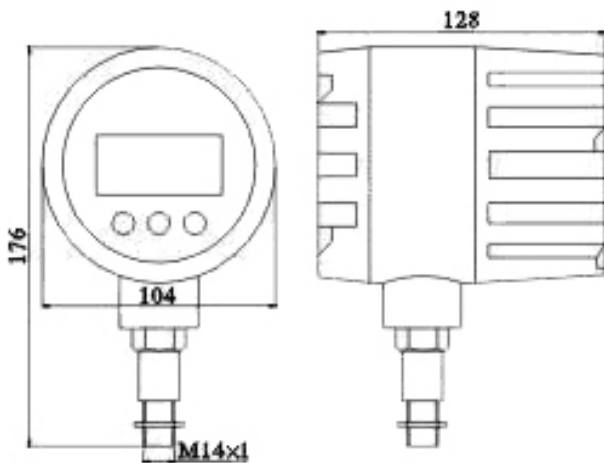

Rate & Total Display
Pulse & 4-20mA Output – 24VDC Powered

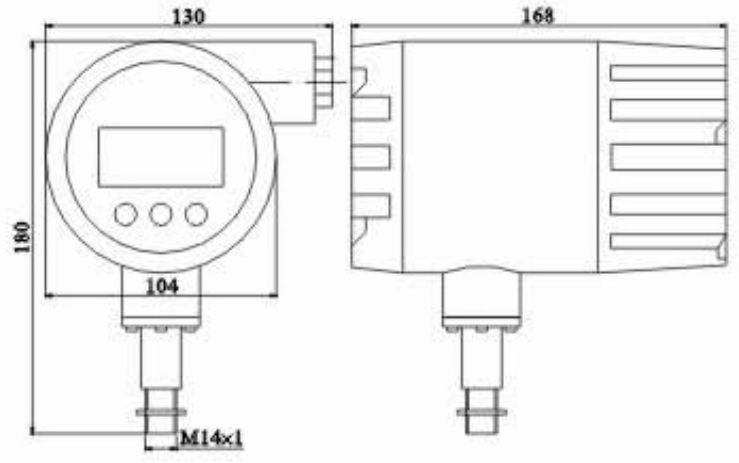

Dimensions of Sensors

Inline Sensors
Screw Connection (DN 2 ~ 25mm)

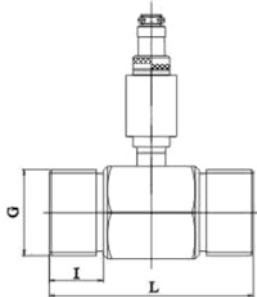

DN (mm)	Connection	I (mm)	L (mm)	Weight (kg)
4	Screw 3/8"	11	42	0.5
6	Screw 3/8"	11	42	0.5
10	Screw 1/2"	16	55	0.6
15	Screw 1"	18	75	1.0
25	Screw 1-1/4"	23	100	1.5

Inline Sensors
Flange Connection (DN 40 ~ 300mm)

DN (mm)	L (mm)	W (kg)
40	140	7
50	150	8
80	200	10
100	220	12
150	300	16
200	360	19
250	400	73
300	420	85

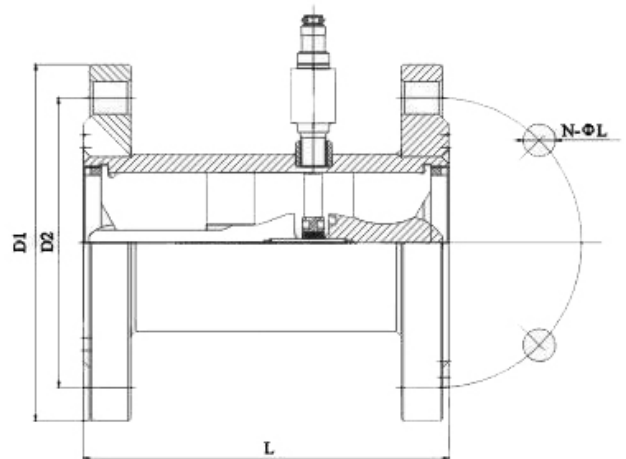

D1, D2, N-ØL and weight can vary according to flange standard required by customer.

Insertion Sensors
(DN 50 ~ 800mm)

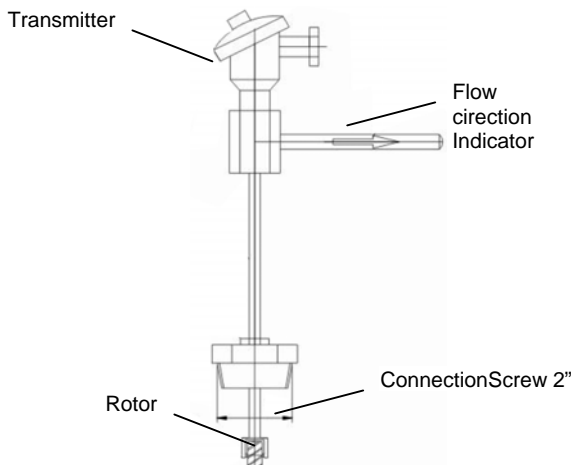

Insertion Sensors
(DN 50 ~ 2000mm)

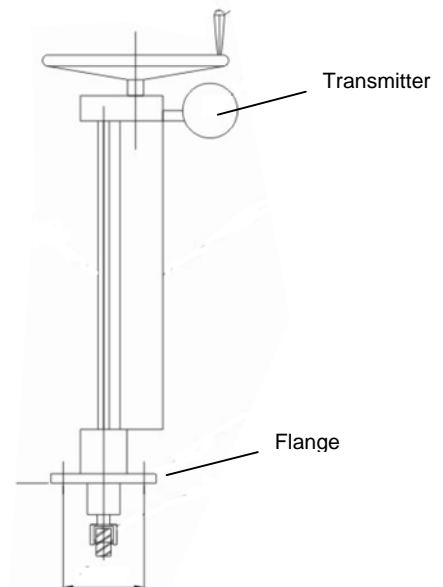



Model Selection Guide

FMT#-###-##-#-##-##-##-Options		Code
Medium	Liquid	FMTL
	Gas	FMTG
DN (mm)		###
Converter/Indicator	No Indicator - Pulse Output Only (Non-Ex-Proof)	T1
	No Indicator - 4-20mA Output Only (Ex-Proof)	T2
	Flow Rate & Total Indicator - No Output (Ex-Proof)	T3
	Flow Rate & Total Indicator – Pulse & 4-20mA Output (Ex-Proof)	T4
Sensor	Inline Sensor	G
	Insertion Sensor	I
Power	24 VDC	P1
	Battery (Lithium Ion - 5 Years)	P2
Connection	Screw (PT, NPT, etc.)	F1
	ANSI 150# Flange	F2
	ANSI 300# Flange	F3
	JIS 10K Flange	F4
	JIS 20K Flange	F5
	DIN Flange	F6
	Sanitary	SA
	Others	—
Output	No Output	NO
	Pulse Output	PA
	4-20mA	AN
Option	Temperature and Pressure Compensation for Gas	GF

Example: **FMT-80-T3-G-P2-F2-NO** : Turbine flowmeter with flanged inline sensor with battery-powered indicator with no output.

Other options may be available. So, please consult with us.

FLOKAL B.V.

Dorpenweg 27 5371 KS Deursen. The Netherlands.

Tel +(31).486.41.6240 Fax +(31).486.41.4514, www.flokAl.eu email info@flokAl.eu